

**CTS - Climatic Test Cabinet Type C -40/100**



- Picture including options (e.g. door with window)



## **CTS - Climatic Test Cabinet Type C -40/100**

Your benefits:

- low power consumption, please see quotation text
- very low-noise level, only 55 dB(A)
- user-friendly and convenient handling and programming with the colour CTS-Multi-Touch panel or with the optional CID-Software on the PC
- uniform operation due to identical operating panel for all cabinets from bench top to walk-in chambers
- temperature measuring with PT 100 in air inlet and air outlet

### **Included in basic equipment**

- operating panel with high resolution colour LCD display for easy handling installed in the front of the cabinet
- defined keys for elementary functions of the cabinet such as start/stop, fixed-value/automatic operation, interruption, light, etc.
- error display in plain text
- potential-free switch contact for heat emitting specimen
- Ethernet - Interface
- 2 digital Out, potential-free, to switch test specimen ON/OFF
- adjustable software-temperature-limiter min./max.
- safety temperature limiter according DIN EN 14597
- maintenance-free capacitive humidity measuring system
- level indicator for the humidification water reservoir in the display panel with warning message
- 1 x shelf, stainless steel, adjustable in height
- 1 x entry port  $\varnothing$  50 mm in the middle of test space on the right side
- door lockable; one-hand operation with integrated safety function to avoid unintentional closing
- international standards are fulfilled (CE-Conformity)

## Technical data

### Temperature tests:

Temperature range	-40°C to +180°C
Temperature fluctuation	$\leq \pm 0,3$ K temporally
Temperature change rate according to IEC 60068-3-5 measured in air inlet	heating: 3 K/min. cooling: 5 K/min.
Heat compensation	approx. max 1200 W at +20°C approx. max 400 W at -20°C

### Climatic tests:

Temperature range	+10°C to +95°C
Temperature fluctuation	$\leq \pm 0,3$ K temporally
Humidity range	10 % to 95 % rel. humidity
Dew point range I	+7°C to +92°C
Dew point range II	-7°C to +7°C
Humidity fluctuation	
Dew point range I	$\leq \pm 1,5$ % rel. humidity, temporally
Dew point range II	$\leq \pm 3$ % rel. humidity, temporally
Note:	The "deep dehu" softkey must be activated to shift into dew point range II. As soon as the shift into dew point range II takes place, the water bath is emptied. At dew point <7°C, the set point only be achieved for a limited time, due to ice formation.

The technical data, especially the performance data, refer to basic cabinet at an ambient temperature of +25°C, nominal voltage of 230V without test specimen, without radiation and without accessories or options, measured in the air inlet.

Options can influence the technical data (e.g. entry port, door with window, notch, bursting disk, etc.) so that the end temperature, temperature change rate and at climate test cabinets the max. climate values could be reduced.

Ambient conditions like temperature and sea level can also influence the performance data.

**Dimensions:**

Test space capacity	100 l
Test space	500 x 400 x 500 mm (W x D x H)
Overall dimensions	see enclosed layout
Dimension for entrance	see enclosed layout
Weight	approx. 360 kg net

**Data for installation and operation:**

Nominal voltage	230 V +6/-10 %, 1/N/PE, 50 Hz
Nominal power	3,4 kW
Nominal current	15,8 A
Connection	Schukostecker
Fuse (on site)	16 A time-lag
Protection class	IP 22
humidification water	consumption max. 1,5 l/h at max. humidification performance demineralized water conductivity max. 10 µS/cm pH-value 6 – 7 water has to be free of algae and pollution

Cooling water: not necessary, or see options

Compressed air: not necessary, or see options

Drain for condensate: pressureless R 1/2",

Note:  
A drain is required by site, also if the option "automatic water replenishment" is ordered

Pressure equalisation: on top of the cabinet

If there can be any emission from test specimen that will cause certain concentration and therefore unacceptable smell to the installation room, the exhausted air of the pressure compensator can be led out by a customer's exhaust air system with an open connection.

The pressure equalizer must never be closed.

**Design:**

Test space	stainless steel V2A, grade 1.4301
Shelf	stainless steel V2A, grade 1.4301, 470 x 360 mm (W x D) max. load of each shelf 35 kg, max. load in total over several shelves distributes 100 kg
Floor load	max. 150 kg/m <sup>2</sup>
Air flow	air inlet and air outlet on the backside of test space
Heating/Cooling	- heating by electrical resistant heaters, made of stainless steel - mechanical cooling by direct evaporation in heat exchanger
Climatic system	- water bath with permanent circulation and automatic water feed from supply tank. - dehumidification via condensation.
Reservoir for humidification water	Convenient filling from the front side
Casing	galvanized steel, resistant powder coating
Colour	casing                               RAL 9006, white-aluminium decorative plates               RAL 9007, grey-aluminium
Door	door can be opened completely hinged on left-hand side, one hand operation lockable
Refrigerating unit	air cooled, low noise refrigeration unit, continuous performance adjustment via electronic monitoring and control system, environmental friendly refrigerants R 452 A based on the current directives and regulations.
Heat dissipation to the installation room	stabilized conditions   approx. 1,5 kW cooling max.                approx. 6 kW
Sound pressure level in accordance to DIN EN ISO 3744	55 dB(A), measured in a distance of 1 m from front
Ambient conditions for operating:	temperature:                   +15°C to +30°C rel. humidity:                20 % to 75 % rel. h. The room must be dry and ventilated. The floor has to be plane.
	Local laws and standards have to be considered by the customer.

## Control

- 32-bit controller
- compatible for all CID-versions
- external control by customer via ASCII protocol, identical for all CTS equipment
- operating panel with glass surface, illuminated from the back and a screen diagonal of 6,8" (17,5 cm)
- multi-gestures display for easy handling
- big colour display with high resolution

## Functions

- customer specified favourite bar
- handling via touch, slide and wipe gestures
- error message in plain text with report function
- graphic curve progressions
- possibility to connect a USB Stick for network independent backup of measurement data, which has to be opened via CID – software
- easy input of test programs
- graphic program preview

## Measurement sensor

- temperature sensor PT 100, DIN EN 60751 or IEC 60751, class A
- humidity sensor with capacitive humidity measuring system, accuracy  $\leq \pm 3,5$  % r. h. in the given climatic range

## Touch-Panel:



Switch contact for  
heat emitting specimen

For heat emitting specimen a potential free contact is included in the basic equipment. In case of an error or at stop of the cabinet the contact opens and the specimen will be switched off to prevent the cabinet from damage with regards to overheating.  
Max. load 230V, 2A.

Digital out

The two digital outs can be set via touch panel or data interface in the manual mode or programmed in a test program. These potential free contacts can be loaded with max. 230V, 2A

Data Interfaces

basic:

- Ethernet – Interface

option:

- RS 485 - Interface
- USB – Interface
- RS 232 - Interface

With all interfaces customer has the possibility to control the cabinet via ASCII-protocol. This means simple commands for default and demand settings like set - and actual temperature, status information or to start and stop the cabinet.

The Ethernet - Interface offers the possibility to integrate the cabinet in an onsite network and offers the additional opportunity to get status information via web browser.

As an alternative the CTS-CID-Software for programming, controlling, measuring and visualization can be used to control the cabinet. The CID- license is available as an option.

With the RS 485 - Interface customer can crosslink up to 32 cabinets over a long distance with a PC.

The USB - Interface will be simulated as a virtual serial Interface on the PC by using the included driver.

**Note:**

Company-specific standards and norms are not considered.

Clarifications with public authorities are on site. Costs are not included in the quotation.

The installation **cannot** be used for tests on explosive, corrosive, toxic or easy inflammable materials or with specimens generating or releasing such materials. This applies particularly to all tests with liquids that boil easily, fuel, hydraulic fluids, lubricants, ammonia, etc. In this case, please pay attention to the information of the material safety data sheet.

The operator has to check the material compatibility of the materials fitted in the testing room (stainless steel 1.4301, non-ferrous metals, aluminium, silicone) to the materials/gases which might be emitted by the test specimen. This can form acids or bases when exposed to humidity. The leaking materials/gases can lead to extensive damage of the equipment.

CTS GmbH will not take responsibility (no warranty) for damages resulting of emission from toxic or aggressive substances from test specimen.



The technical design of the unit with regards to basic security and health requirements refers to the following directives and standards:

### **Directives and National Legislation**

Machinery directive 2006/42/EC  
EMC directive 2014/30/EU  
Pressure equipment directive 2014/68/EU

### **Mechanical Standards**

EN ISO 13857 (issue 06/2008)  
EN 378-1,-2 (issue 04/2018)  
EN 378-3,-4 (issue 03/2017)  
EN ISO 13732-1 (issue 12/2008)  
EN ISO 12100 (issue 03/2011)  
AD2000 (issue10/2000)

### **Electrical Standards**

EN ISO 13849-1 (issue 12/2008)  
EN ISO 13849-2 (issue 02/2013)  
EN 61000-6-2 (issue 03/2006)  
EN 61000-6-3 (issue 09/2011)  
EN 61010-1 (issue 07/2011)  
EN 61010-2-010 (issue 06/2004)  
VDE 0100-410 (issue 06/2007)  
DGUV regulation 3

**Layout of CTS-Cabinets, Test space volume 100 l**

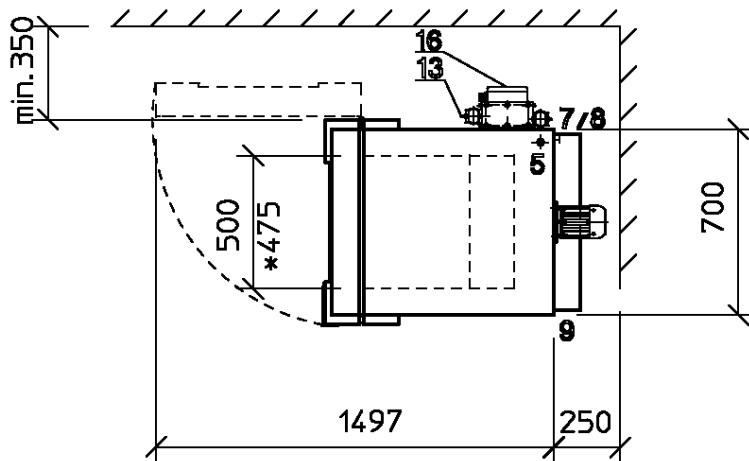
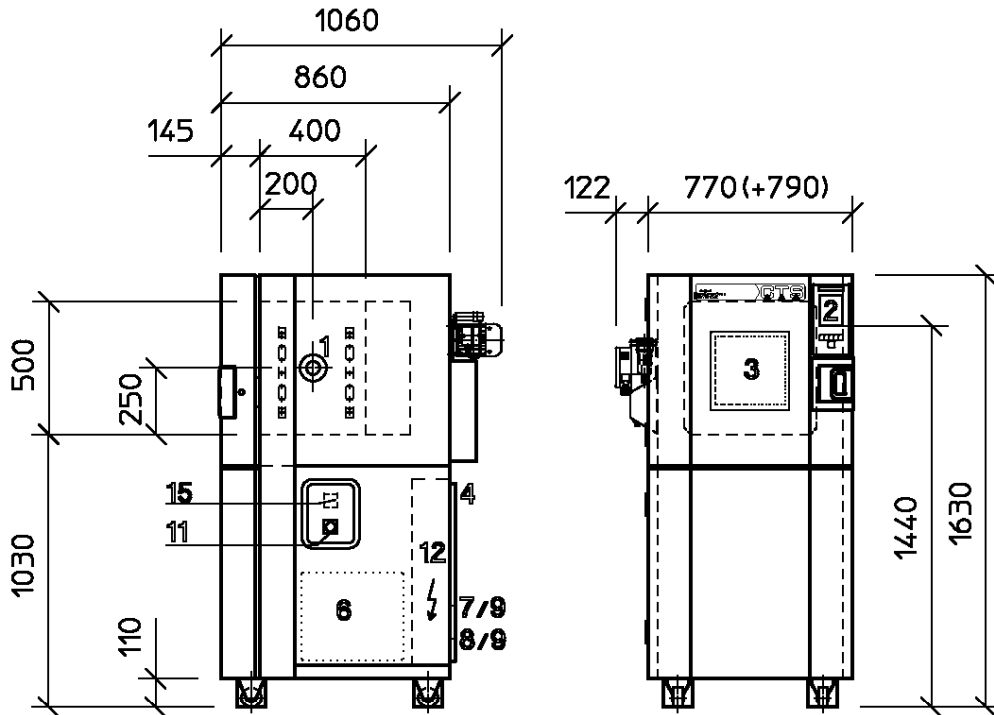

- 1 Entry port Ø 50 mm
- 2 Control panel
- 3 Window 300 x 300 (option)
- 4 Electr. Connection cable, length 5 m
- 5 Pressure equalizer
- 6 Area for outlet of cooling air, both sides
- 7 Drain of test room R 1/2"
- 8 Water-inlet demi-water R 1/2" (option)
- 9 Cooling water connections R 1/2" (option)
- 11 Main Switch
- 12 Control unit
- 13 Compressed air inlet, coupling with hose connection Ø 9 mm (option)
- 15 Operating temperature limiter (option)
- 16 Compressed air dryer (option)

\* clearance width/high  
+ entrance clearance