



FT10-series

User Manual

FT10-IS, FT10-ES, FT10-CS, FT10-RHT, FT10-RT433

Contents

Document information	2
Introduction.....	3
Warnings.....	3
Trademarks.....	3
Manufacturer	3
Description	3
Installation.....	5
Troubleshooting	9
Maintenance.....	10
Recalibration.....	11
Configuring	13
Specifications.....	16

Document information

Device Scope:	FT10-series
Firmware Versions:	1.0 to 2.3
Document Type:	manual
Document ID:	2368
Document Version:	27
Document Date:	19.3.2015

Introduction

FT10 is a modular transmitter series belonging to the **Nokeval OVA** product family. FT10 series wireless transmitters consist of a radio transmitter module **FT10-RT433** and a measuring module. Keeping the transmitter certifiably calibrated is easy and economical thanks to the easily replaceable measuring module. It can be hot-swapped anytime with a factory calibrated replacement measuring module sent in advance to the installation location, without even causing a break in the measurements. The design and construction of the series gives the devices high measuring accuracy and stability along with outstanding durability and resistance against adverse environmental conditions.

This manual covers all FT10 series measuring modules available at the time of printing:

- **FT10-IS:** Temperature measurement with internal Pt100 temperature sensor
- **FT10-ES:** Temperature measurement with external Pt100/Pt1000 temperature sensor
- **FT10-CS:** With M12 connector for external Pt100/Pt1000 temperature sensor
- **FT10-RHT:** Relative humidity and temperature measurement combined in the same unit

Warnings



FT10 series devices contain a primary battery and a low-power license-free ISM band radio transmitter operating at 433.92 MHz. Observe local regulations concerning the proper disposal of batteries and the use of the integrated radio transmitter.

Trademarks

Any trademarks mentioned in this manual are the property of the respective trademark owners.

Manufacturer

Nokeval Oy
Rounionkatu 107
FI-37150 Nokia
Finland

Phone +3583 342 4800 (Mon-Fri 8:30-16:00)
WWW <http://www.nokeval.com/>
Email sales@nokeval.com, support@nokeval.com



Description

General

FT10 series modules are housed in impact resistant plastic enclosures which, when properly connected together, are watertight to IP 66. The joint between the two modules is sealed with two rubber O-rings. The devices fulfill the mechanical and measuring accuracy requirements of the **EN 13485** standard. They also conform to the requirements of the standards **EN 13486** and **EN 12830** where applicable.

A complete FT10 series transmitter always consists of a transmitter module FT10-RT433 and one of the measuring modules. The name and order code of the complete product is formed by combining the names of the modules as in the following examples:

FT10-RT433 + FT10-IS = FT10-RT433-IS

FT10-RT433 + FT10-RHT = FT10-RT433-RHT

FT10-RT433

This is the radio transmitter module that is compatible and interchangeable with all FT10 series measuring modules. It operates on the power supplied by the battery located in the measuring module and sends the measurement results wirelessly over the **433.92 MHz** license-free ISM (Industrial, Scientific and Medical) band. The transmitting frequency and power have been carefully selected so that wireless measurements are possible even from closed cold storage rooms with stainless steel walls. The power consumption of the radio transmitter is so low, however, that it does not cause any adverse effects to living organisms or to other nearby radio devices operating on other frequencies.

Each radio transmitter module has a unique ID number that is used to distinguish the measuring results coming from each individual transmitter. The device is attached to the measuring target from the radio transmitter module's mounting flanges, so when the measuring module is replaced the ID number does not change.

FT10-IS

This module measures the ambient temperature using its **internal Pt100** temperature sensing element, a 24-bit AD converter, a micro controller and a 1.5 V size AA alkaline battery. In typical use the endurance of the battery is over two years which is longer than the predefined two-year calibration period of the measuring module. Temperature measuring accuracy and stability of the device is very good. All units are factory calibrated and individually adjusted for guaranteed **accuracy better than ± 0.5 °C** over the temperature range of -30...+50 °C.

Nokeval offers a very competitively priced calibration service for this measuring module type. The calibration service is implemented with factory calibrated replacement measuring modules. The old modules can be returned to the factory after the new ones have been received and installed, and only a calibration fee will then be charged.

FT10-ES

This module measures the temperature with an **external Pt100** temperature sensor. The measurement technique is the same as in FT10-IS. The module can be ordered preinstalled with one of several different types of Pt100 sensors or it can be ordered without a sensor. The module can also operate with most other common resistive temperature sensing devices, e.g. **Pt1000**, **Ni** or **Cu** sensors. The sensor is connected

directly to the circuit board of the measuring module with a spring loaded quick connector and the cable is routed through an M12 gland in the rear of the enclosure which provides sealing to IP 65.

FT10-CS

This module is identical in operation and specification with FT10-ES with the exception that this module has an externally accessible standard 4-pole M12 sensor connector (receptacle) mounted on the rear of the enclosure. The module is supplied together with a compatible M12 plug connector which can be used to connect the sensor.

FT10-RHT

This module measures both ambient temperature with an integrated Pt100 temperature sensing element and relative humidity with a modern digital capacitive humidity sensor module. The humidity sensor is mounted on a circuit board protruding from the bottom of the module. This circuit board and sensor are protected with a replaceable filter element. The selected filter type defines the sealing class of the device and also determines the response time of the humidity sensor and the type of environment where the transmitter can be operated.

Just like other FT10 series measuring modules the FT10-RHT sends the temperature reading with the ID marked on the connected radio transmitter module **but the humidity reading is sent with ID+1000.**

Installation

Preparations

The devices are delivered with the measuring and transmitter modules separated in order to conserve the batteries during storage and transport. The device will start to measure and transmit as soon as the two modules are put together. Prior to installing the radio transmitter modules at their target locations, the devices should be put together and it should be checked that each device starts to transmit.

When putting the modules together, make sure that the two parts are pushed together all the way so that the **locking latches snap into position**. This is important for ensuring the watertight sealing of the modules. It is also important because when the temperature rises, the pressure inside the device will rise slightly as the air caught inside cannot expand in the sealed space. Rising pressure could eventually push the modules apart and compromise the sealing, if the latches are not properly locked.

It's always a good idea to make an installation plan of all the target locations and their names. It is then easy to write down the ID numbers of the transmitters that are installed in these places.

Maximum number of transmitters

International radio standards limit the use of radio frequencies and they also limit the use of the license-free ISM frequency band that Nokeval transmitters use. The maximum total number of Nokeval radio transmitters that can be simultaneously used in the same coverage area depends on the transmit interval. The following table gives guidelines on the maximum number of transmitters with different setups. The default interval is 80 seconds for FT10-IS and FT10-RHT, and it is 40 seconds for FT10-ES and FT10-CS. Transmit interval can be individually adjusted for each transmitter as instructed in the chapter Configuring.

Interval	Receiver(s) only	Receiver(s) and 1 repeater	Receiver(s) and 2 repeaters
5 s	22	11	7

10 s	43	22	14
20 s	87	43	29
30 s	130	65	43
40 s	174	87	58
50 s	217	109	72
60 s (1 min)	261	130	87
70 s	304	152	101
80 s	348	174	116
90 s	391	196	130
120 s (2 min)	522	261	174
240 s (4 min)	1043	522	348

Dimensions

The dimensions of the device (FT10-RT433-IS) in the operating condition are given in the following picture. The length of the device is 352 mm which includes the flexible antenna. The length of the device is dictated by the wavelength of the radio signal. The size of the antenna must be in correct proportion to the wavelength to achieve the best possible range. The dimensions are nearly the same or smaller than the dimensions of the predecessor device MTR260C. The size of the unit is minimized so as to not compromise the other performance figures of the device. It should fit into most commercial and industrial refrigerators and freezers that are not filled over the limit recommended by the manufacturer of the cold storage appliance.

There are two mounting holes on the flanges of the transmitter module which have a diameter of 4.7 mm. The distance between these two mounting holes is 50 mm. For mounting the assembly, use these mounting holes and screws with a maximum diameter of 4 mm. Select the type of screw according to the material where the transmitter is to be mounted on.

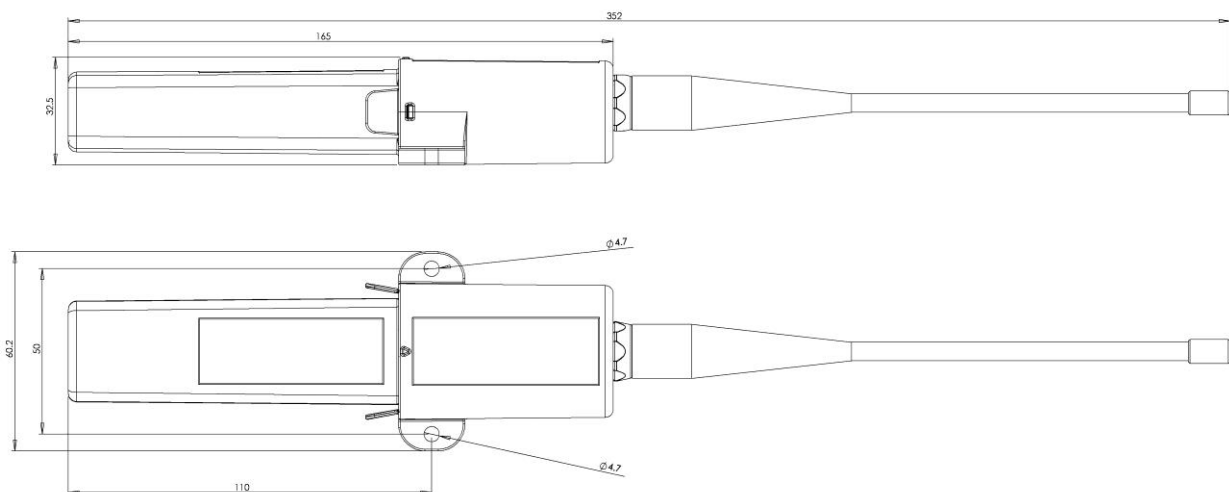

Mounting location

Radio technical perspective

FT10-RT433 radio transmitter has a typical *indoor maximum range* of 50...100 m depending on the number and quality of obstacles between the transmitter and the receiver. The best range is achieved when there is a line-of-sight between the transmitter and receiver. In unrestricted open space (outdoors) the maximum range can be over 1000 meters. Walls and obstacles attenuate the signal and therefore reduce the range. Especially closed steel structures attenuate radio signals very effectively, and installation in or behind them should be avoided if possible. In the worst possible conditions, e.g. very thick reinforced concrete walls, bomb shelters, deep underground spaces, the range can be even less than 10 meters.

However, most spaces with metal walls have doors or openings of some sort, and these openings and the seals between them and the door, leak radio signals if the seals are made of non-conductive material. As a rule of thumb the device should be mounted with antenna positioned vertically just like the antenna of the radio receiver. The doors that leak the radio signals usually have larger vertical dimensions than horizontal and thus leak the vertically polarized signal from the vertically mounted antenna more effectively.

The antenna should never be installed flat against a conductive (metallic) surface. Direct contact of the antenna with a metal surface heavily attenuates the transmission and dramatically reduces the range. If possible, there should be an air gap of at least one or two centimeters all around the antenna. Practical experience has however shown that radio reception has been flawless from a transmitter completely covered in frozen vegetables for example.

One more factor that affects the final transmission range and performance is the local radio interference and noise condition. This should be seriously considered in heavy industrial installation sites or any sites with lots of power electronics around, for example power inverters and large electric motors. At least the radio receiver should be located as far as possible from this type of radio interference sources.

In any case, it is worth considering the installation location from the radio technical perspective too. For the FT10-IS and FT10-RHT the primary guide in selecting the installation location should always be the measurement perspective. The models with external sensor (FT10-ES and FT10-CS) give more flexibility in choosing the installation location of the transmitter itself. But even for these, the guidelines given in the next chapter should be followed when choosing the installation location for the external sensor.

Measurement perspective

FT10-IS and FT10-RHT must always be installed into the location whose temperature and/or humidity is to be measured, because the devices measure their own internal temperature. The device itself does not generate heat and therefore its internal temperature stabilizes to the ambient temperature. The mass of the device causes a certain amount of delay and filtering from ambient temperature changes. This is a designed feature that attenuates rapid temperature fluctuations that could cause false alarms in the temperature surveillance system. Causes of these rapid temperature fluctuations include opening doors, defrosting cycles, compressor operating cycles and persons moving nearby. The temperature response time of FT10-IS and FT10-RHT is about 15 minutes, which is still short enough for the intended purpose when a real alarm condition occurs. If this response time is too long for the application, consider using FT10-ES or FT10-CS models instead where the response time is dictated by the selected external temperature sensor.

When choosing the installation location one must consider multiple effects affecting the temperature distribution in the space. Air tends to layer such that cooler air is lower and warmer air is higher. Evaporators and fans blow cold air into their vicinity. Doors, vents, lamps and other heat sources warm up their surroundings. The device or external sensor should be installed into a spot whose temperature follows as closely as possible to the temperature of the target products in the same space. Therefore the device or the sensor should **not be installed:**

- close to the floor or ceiling,
- onto the floor or ceiling,
- near the evaporator of a refrigeration unit,
- near the place where the cold/hot air flows from the evaporator/radiator,
- near a door or other opening and definitely not above one,
- close to a lamp or other heat source nor
- in a location where it is likely that the device will be covered up or get mechanically damaged.

A good installation location is:

- on a wall as far away as possible from the door and the evaporator/radiator,
- at a height of about 3/4 of the height of the space,
- and where people rarely move about,
- and where air can freely move around.

Connections

FT10-RT433

The radio transmitter module has an external antenna connector which is a standard 50-ohm BNC receptacle. This connector is intended only for the standard antenna which is supplied with each transmitter module. The antenna is connected by pushing it onto the BNC receptacle and then turning the antenna about 90 degrees clockwise while holding and pressing it from the thick end. The antenna locks into position. The antenna can be removed by turning the antenna 90 degrees anti-clockwise. The antenna must always be connected to the transmitter module when it is in operation.

FT10-IS

This measuring module does not have any external connections.

FT10-ES

This measuring module has an external cable gland for mounting the sensor cable. The sensor connector J4 is on the circuit board inside the enclosure. This connector has four spring loaded contacts. To connect a sensor wire, first push down the small orange tab above the connector cavity and then insert the sensor wire all the way into the cavity. When the orange tab is released, the sensor wire should be locked into the connector. Test this by gently pulling the sensor wire. It should not move out of the connector.

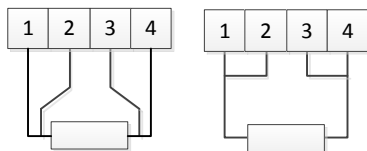

Connect the sensor wires according to this diagram.

Note that if a 2-wire sensor is used, poles 1 and 2 must be shorted together and poles 3 and 4 must be shorted together also.

FT10-CS

This measuring module has a standard 4-pole M12 sensor connector for attaching the sensor. A compatible M12 plug is supplied with the module. Refer to the following illustration for the pin out of the M12 connector on the transmitter. Connect the sensor wires to the plug accordingly.

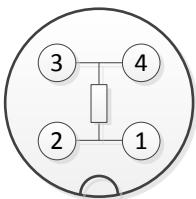

The M12 connector is seen here looking in to the receptacle connector of the measuring module. Use the numbering as a guide when connecting the sensor wires to the M12 plug connector. Note that if a 2-wire sensor is used, poles 1 and 2 must be shorted together and poles 3 and 4 must be shorted together also.

FT10-RHT

This measuring module does not have any external connections. However, the filter element protecting the humidity sensor can be replaced. It is replaced by turning it anti-clockwise until it detaches. A new identical filter element or a different type of compatible filter element can be attached by turning it clockwise until its rubber O-ring is sealed against the filter attachment assembly.



Do not touch and do not allow the filter element to touch the electronic components on the humidity sensor circuit board which is exposed when the filter element is removed.

Do not over-tighten the filter element to avoid damaging the plastic threads of the attachment assembly.

Troubleshooting

No radio reception

If the radio packets of this transmitter cannot be received and the operation of the receiving system has already been verified according to their manuals and preferable also with a transmitter known to work, then the following should be checked:

1. Some transmitters have an integrated piezo speaker which will emit a short “tick” sound every time a radio packet is sent. Listen to the radio transmitter closely to hear the ticks in order to verify that the transmitter is operating.
2. Some transmitters have an LED inside the measuring module that will blink every time a radio packet is sent. Look closely into the side of the measuring module’s enclosure to see the LED blink.
3. If the above checks fail, detach the measuring module from the transmitter module and connect a programmer or POL programming cable to the round programming socket and check the battery voltage from the menu. For more information on programming cables and configuration menu, refer to chapter Configuring.
4. If configuration attempts fail, open the measuring module’s enclosure as instructed in chapter Maintenance > Replacing the battery. Reinstall the old battery in its holder to rule out any contact disturbances and try configuring the device again.
5. If the device still fails to respond to configuration attempts, replace the battery with a new one and retry configuring.
6. If the transmitter is working and the battery is found to be fine, then try reorienting or relocating the transmitters and/or the receiver to improve radio reception. For more information on this topic refer to chapter Installation > Mounting location.

Erroneous readings

If the received readings are obviously wrong or intermittent, first check the condition of the sensor, sensor cable and connection to the measuring module. Check also that the temperature is within the measuring range of the transmitter. Finally check the sensor and calibration settings of the measuring module.

Maintenance

Cleaning

The plastic parts can be cleaned with a soft cloth and soap water. Cleaning with isopropyl alcohol is also allowed.



When cleaning with liquids make sure that the transmitter and measuring modules are properly connected together to prevent liquids from entering the enclosures.

Battery

General

FT10 series devices are powered by a single 1.5 V size AA alkaline battery. The battery comes preinstalled inside the measuring module. The measuring module is in a low-power inactive state as long as it is not connected to the transmitter module. When the modules are connected together, the measuring module wakes up and begins to provide power to the transmitter module. If the modules are separated again, the measuring module immediately returns to the low-power state to conserve battery power.

Endurance

Battery life time depends on the used transmit interval. Ambient temperature also has an effect on the achievable battery life, which will be significantly shorter in extremely cold and very hot environments. The following graph gives a rough estimate of battery life with different transmit intervals. It should be noted that with long transmit intervals, the estimated battery life approaches the typical shelf-life of alkaline batteries. Thus also the age and quality of the battery affect the resulting battery life time.

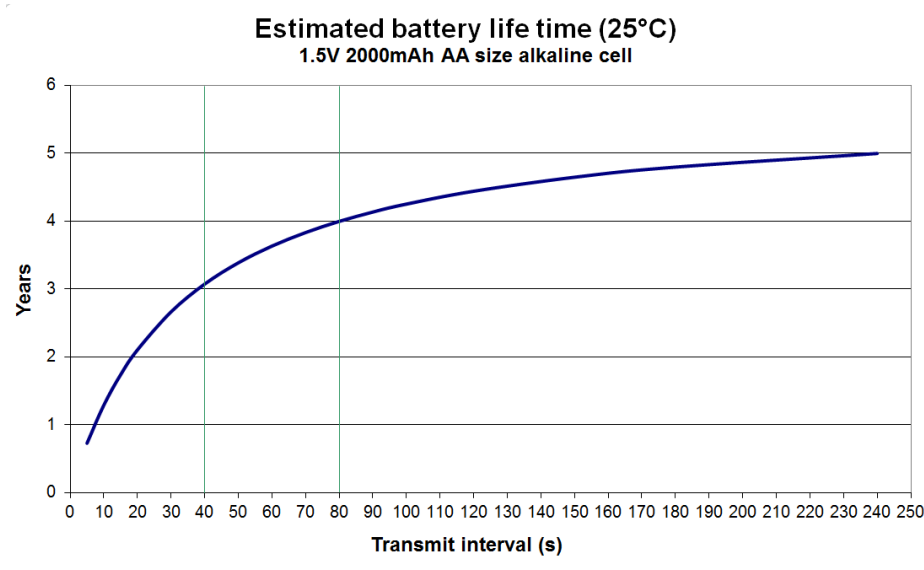

Replacing the battery

It is rarely necessary to replace the battery because of its long life and because it's always replaced as part of the factory recalibration procedure. However, the battery is user replaceable but it should be done very carefully. To replace the battery, follow these steps:

1. Detach the measuring module from the transmitter module
2. Have a medium size flat-bladed (if possible, not too sharp) screwdriver at hand

3. Detach the cover from the measuring module by pressing it with the screwdriver through the small hole on the enclosure of the measuring module and the cover should pop out
4. Carefully pull out the circuit board
5. Replace the battery with a high quality alkaline 1.5 V size AA battery **observing the correct polarity**
6. Carefully insert the circuit board all the way back into the enclosure by pushing it between the guide rails inside
7. Reinstall the cover plate observing the correct orientation of the holes
8. Plug the measuring module back into the transmitter module
9. Properly dispose of the used battery observing the local regulations

Recalibration

General

FT10-IS, **FT10-CS** and **FT10-ES** measuring modules have a predefined calibration period of two years.

FT10-RHT measuring modules don't have a predefined calibration period. **FT10-RT433** radio transmitter modules don't need calibration at all, because they have no effect on the measuring accuracy. Each measuring module has a silver colored type label attached (see picture below) that has the calibration date (**Cal. date:**) and the next calibration date (**Cal. due:**) printed on it. The calibration is most preferably implemented as a subscribed service where factory calibrated replacement measuring modules are first sent to the customer who then returns the replaced old modules in the same packaging to the sender. If there is no calibration subscription, then the calibrated replacement modules can be separately ordered. For more information, please visit our web pages at address www.nokeval.com and select **Support** (top of the page) and then **Calibration** (left side). The availability and pricing of the calibration subscription service depends on the destination country.



Delivery of replacement measuring modules

Replacement measuring modules are delivered in practical customized packaging that is to be used for the return shipment of the old replaced modules. Freshly calibrated modules can be picked up from the package on-site and the old modules immediately returned to the places where the new modules were taken from. The packaging includes a return address slip for most convenient return shipment.

Detaching a measuring module

Measuring module is detached from the radio transmitter module as follows. First grasp the measuring module from the locking latches and fully depress them to release the latches. Then pull the measuring module straight out of the transmitter module. You may need to wiggle the measuring module slightly to more easily overcome the friction caused by the two rubber O-rings. If necessary, support the radio transmitter module by holding it in place with your other hand at the same time when pulling out the measuring module.

Reattaching a measuring module

Measuring module is attached to the radio transmitter module as follows. First align the small embossed arrowheads on both modules' housings (when they are aligned, also the silver colored labels on both modules are on the same side). The measuring module is then pushed straight into the transmitter module until the locking latches catch and click into place. Measuring starts immediately. For more information refer to page 4, topic Preparations.

Important note on temperature stabilization

Depending on the temperature where the calibrated replacement modules were stored prior to installing them, there is a **possibility of false temperature alarms** from the final surveillance system. This is because it takes up to 15 minutes for the measuring modules to reach the temperature of the final installation location. If the surveillance system is set up so that this scenario is likely to cause false alarms or other harm, it is recommended to let the calibrated measuring modules' temperature stabilize for at least 15 minutes near the final installation location prior to installation.

Calibration certificates

Individual calibration certificate is available for each calibrated FT10 series measuring module. To avoid printing, handling, sending and storing a large number of paper certificates that are easily misplaced, all calibration certificates are always available on Nokeval web site at address www.nokeval.com. On the pages select **Support** (top of the page) and then **Calibration** (left side). Finally select the item **Calibration certificates**. See the picture below.

Enter the serial number of the measuring module in question into the text entry box. The serial number has the format of A123456 or P123456. The serial number of each measuring module can be found on the silver colored type label, just below the bar code, right after **S/N:**. After entering the serial number just click the button "**Get certificates**". Now you will see a list of certificates with corresponding dates. Click the PDF link next to the date to download and view the certificate. Adobe Reader is needed to view the certificates, it can be downloaded at get.adobe.com/reader.

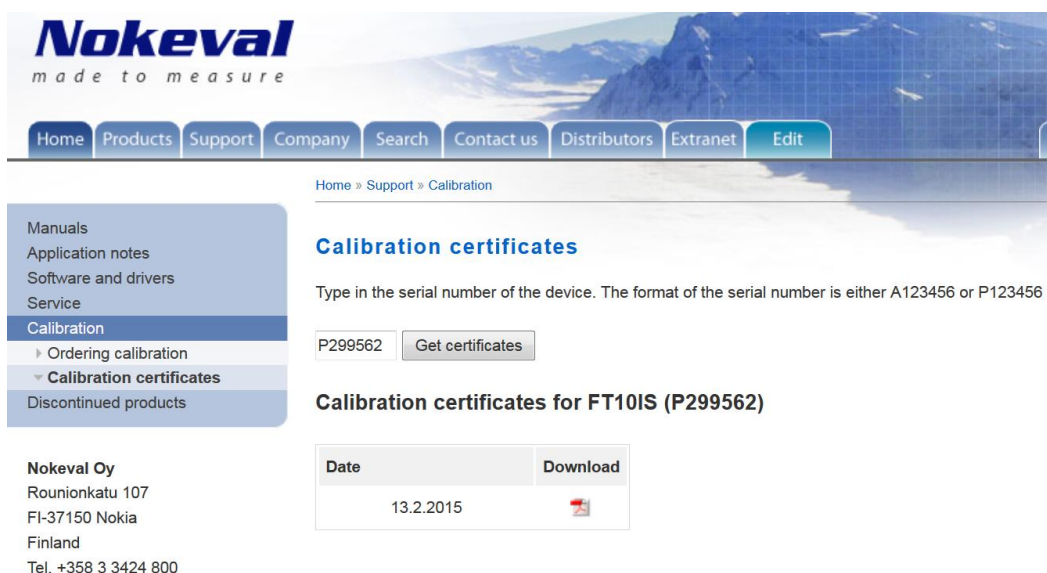

Nokeval
made to measure

Home Products Support Company Search Contact us Distributors Extranet Edit

Home » Support » Calibration

Calibration certificates

Type in the serial number of the device. The format of the serial number is either A123456 or P123456

P299562

Calibration certificates for FT10IS (P299562)

Date	Download
13.2.2015	

Nokeval Oy
Rounionkatu 107
FI-37150 Nokia
Finland
Tel. +358 3 3424 800

Configuring

Programming cable

FT10 series measuring modules feature a round 3.5 mm POL programming connector jack found on many other Nokeval products as well. The measuring module must be detached from the radio transmitter module in order to be able to connect the programming cable.

Two types of programming cables are available:

- POL-RS232 for the RS-232 port of the computer.
- DCS772 for the USB port of the computer (recommended).

A free Windows software Nokeval Mekuwin is used for configuring. About using Mekuwin, refer to its documentation. The contents of the configuration menu are described in the next chapters.

The communications parameters are always:

Protocol **SCL**
Baud **9600**
Parity **8N1**
Address **0**

Menu

All measuring module types have the same menu structure which is illustrated below. Normally only the Conf and Mon menus are shown. A password is required to change the settings in the Cal menu to prevent inadvertent changes. The password for the Cal menu is NAPPI.

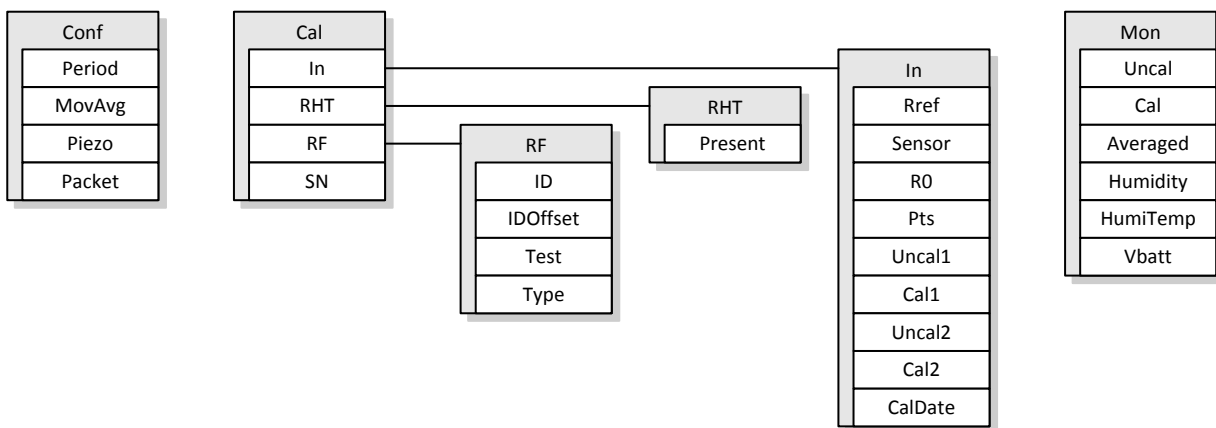

Conf submenu

Period

This sets the transmit period or interval of all measurement results. Allowed range is from **2 to 127 units**. This corresponds to an approximate range of **5 seconds to 5 minutes and 43 seconds** because each unit represents about **2.7 seconds** in room temperature. Actual transmit interval varies slightly depending on ambient temperature. This variation is intentional to reduce the chance of collisions between transmitters.

This setting has a direct effect on battery endurance. Avoid using unnecessarily short transmit intervals because this causes the battery to drain faster and also limits the maximum number of wireless

transmitters that can be used in the same coverage area. Refer to the Maintenance chapter's Battery topic (page 9) for more information on battery endurance and maximum number of transmitters.

MovAvg

When this option is turned on, moving average filtered results will be transmitted. This reduces flicker in the transmitted results but also increases the response time. The filtering is done over 10 most recent measuring results.

Piezo

When this option is turned on, a small piezo speaker inside the measuring module emits a sharp beep each time a measuring result is sent. Not all measuring modules contain this piezo speaker, and when this is the case, the Piezo option has no effect.

Packet

Normally this option is set to dK, and the FT10 will transmit the temperature in decikelvins at 0.1 °C resolution. For more resolution, this option can be changed to Float, giving more than enough resolution at a cost of a slight battery life decrease. Not available before firmware V2.3.

Cal submenu

This submenu requires the password NAPPI to be entered before the settings can be changed. In case of **FT10-IS** and **FT10-RHT** the settings in this menu should not be changed, they are reserved only for factory calibration. In the case of **FT10-ES** and **FT10-CS** the settings Sensor, R0, Pts, Uncal1, Cal1, Uncal2 and Cal2 in the In sub-submenu can be used to select the correct sensor type and to calibrate and trim off the sensor error. The other sub-submenus RHT, RF and SN contain settings that are strictly reserved for factory use and should never be altered.

Rref

This setting is reserved for factory calibration only.

Sensor

This setting selects the sensor linearization method. Possible values are **Pt**, **Ni**, **Cu** and **Ohm**.

Value	Description
Off	Sensor not used. Uses the humidity sensor temperature if available.
Pt	Standard platinum RTDs (IEC 60751)
Ni	Nickel RTDs
Cu	Copper RTDs
Ohm	No sensor linearization, result of resistance measurement is sent in Ohms

R0

This setting defines the resistance of the sensor element in reference temperature (0 °C). For Pt100 the default value is 100 and for Pt1000 it is 1000. If a more accurate value is known for the sensor in question, it can be entered here to obtain more accurate results.

Pts

This setting selects the used calibration mode. Possible values are **0**, **1** and **2**. See the table below.

Value	Description
0	No calibration is applied
1	One-point (offset) calibration is used (Uncal1 and Cal1 settings are visible)
2	Two-point calibration is used (Uncal1, Cal1, Uncal2 and Cal2 settings are visible)

Uncal1, Cal1

Calibration data for one-point calibration or the first calibration data point for two-point calibration. Uncal1 is the uncalibrated reading that was obtained from the device when the calibration reference's reading was Cal1. The unit of Uncal1 is °C for Sensor-settings Pt, Ni, Cu and Ohms for Sensor-setting Ohm. Unit of Cal1 is the same as the unit that was used for calibration reference.

Uncal2, Cal2

This is the second calibration data point for two-point calibration. Uncal2 is the uncalibrated reading that was obtained from the device when the calibration reference's reading was Cal2. The unit of Uncal2 is °C for Sensor-settings Pt, Ni, Cu and Ohms for Sensor-setting Ohm. Unit of Cal2 is the same as the unit that was used for calibration reference.

CalDate

This setting contains the date of the last factory calibration. This date information is sent with the radio transmitter once after each 100 measurements.

Mon submenu

This submenu shows some information for monitoring the operation of the device. It does not contain settings that can be changed.

Uncal

This is the pure sensor linearized but uncalibrated measurement result.

Cal

This is the measurement result after the selected calibration method (see Cal submenu item Pts). This result is sent with the radio transmitter if the MovAvg option is off.

Averaged

This is the measurement result after moving average filtering the Cal results. This result is sent with the radio transmitter if the MovAvg option is on.

Humidity

This is the final humidity measurement result from the digital humidity sensor. This result is sent with the radio transmitter with ID number that has 1000 added to the ID that is marked on the label of the radio transmitter module. This is valid for **FT10-RHT** only.

HumiTemp

This is the temperature as measured by the digital humidity sensor. This is the temperature reading that will be sent when Sensor option is set to Off in an **FT10-RHT**.

Vbatt

This is the measured battery voltage. The nominal voltage of the battery is 1.5 V. When new, the battery may yield almost 1.6 V. The battery is exhausted when the voltage drops below 0.9 V.

Specifications

FT10 Series

Environmental

Operating temperature	-30...+60 °C
Storage temperature	-40...+70 °C
Humidity	max 95 %RH non-condensing
Case material	Radio transmitter: PC Meas. modules: ABS+PC

External dimensions

Length (includes antenna and connector)	352 mm for FT10-RT433-IS 374 mm for FT10-RT433-ES 435 mm for FT10-RT433-CS 392 mm for FT10-RT433-RHT
Width	60.2 mm
Height	32.5 mm

Power supply

Battery	1.5 V type LR6 (AA) alkaline battery, heavy-duty
---------	--------------------------------------------------

Regulatory information

EMC immunity	EN 61326
EMC emissions	EN 61326, class B
R&TTE directive	EN 300 220, class 3, transmitter power class 8 EN 301 489 EN 300 339
EC regulation 37/2005	EN 13485 EN 13486 EN 12830

FT10-RT433

Radio transmitter

Type	License free 433.92 MHz ERC/REC/70-03 sub band f
Frequency band	433.92 MHz ISM band
Power	+10 dBm E.R.P. maximum
Open space range	1000 m maximum
Indoor range	50...100 m typical
Antenna	Use only the supplied dedicated antenna
Compatible radio receivers	Nokeval MTR, RTR, FTR, DPR and FT20 series 433.92 MHz radio receivers

FT10-IS

Ambient temperature measurement

Sensor type	Integrated Pt100 element
Measuring range	-30...+60 °C
Accuracy	±0.5 °C over -30...+50 °C
Step response time	15 min to 90% (MovAvg=Off)

Environmental

Protection class	IP 66 (when connected)
------------------	------------------------

FT10-ES, FT10-CS

External temperature sensor measurement

Sensor type	Pt, Ni, Cu resistive temperature sensor
Cable length	< 3 m (for specified perf.)
Measuring ranges	Pt100: -200...+600 °C Ni100: -60...+180 °C Cu: -200...+260 °C
Accuracy (4-wire)	0.05% rdg + 0.2 °C at 25 °C
Thermal drift	0.01 °C/°C ref 25 °C ambient

Environmental

Protection class	IP 65 (when connected)
------------------	------------------------

FT10-RHT

Ambient temperature measurement

Sensor type	Integrated Pt100 element
Measuring range	-30...+60 °C
Accuracy	±0.5 °C over -30...+50 °C
Step response time	15 min to 90% (MovAvg=Off)

Relative humidity measurement

Sensor type	Capacitive element
Measuring range	0...100 %RH non-condensing
Total error band (TEB)	±5 %RH over 10...90 %RH and +5...+50 °C
Typical accuracy	±3 %RH over +0...+50 °C
Step response time	10 min to 63 % 25 min to 90% with standard sintered filter

Environmental

Protection class	IP 40 (when connected)
------------------	------------------------